

ORLEN Unipetrol RPA s.r.o.	Závitové nátrubky tvarovek a kolen	N 16.6

★ DETAIL
DRÁŽKY

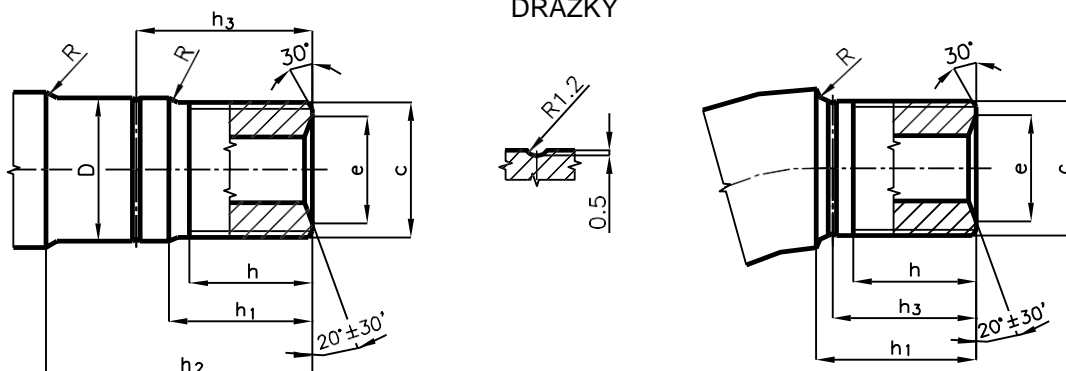

DN	ROZMER		TVAROVKY						KOLENA			
	c	e	D	h	h ₁	h ₂	h ₃	R	h	h ₁	h ₃	R
6	G 3/8"	10	18	25	30	42	35	3	22	30	27	3
10	G 3/4"	18	28	28	33	60	41	3	28	33	30	3
16	G 1"	26	35	30	35	65	43	3	30	38	35	3
24	G 1 1/4"	35	45	32	37	75	45	3	32	44	37	5
30	G 1 1/2"	43	50	35	40	82	48	5	35	46	40	5
45	G 2 1/4"	60	70	45	50	95	58	5	45	60	52	5
58	IG 89x1/8"	76	95	55	60	95	75	5	50	65	57	5
70	IG 101x1/8"	92	105	65	70	105	85	5	62	72	67	10
90	IG 125x1/6"	116	130	70	78	115	93	5	70	83	75	10
120	W 169x1/6"	152	175	95	105	140	125	5	85	105	92	10
160	IG 225x1/4,5"	202	230	125	140	175	160	5	115	140	125	10
200	W 284x1/4"	250	288	150	165	225	190	5	150	160	155	10

★ Závitové nátrubky z ocelí tř.15 (N) musí být označeny drážkou

Nahrazuje : N 16.6 z 10/1970	Správce normy : Sekce podpory údržby	Platnost od : 1.7.1999 (Aktuálnost ověřena 2.2.2022)
---	--	--